



NTS 2 White Muffin Tray 3x4

NTS Series

Technical Data - Individual Cup

G9F12005

		Tolerance
Bottom (A)	50 mm	± 1 mm
Top (B)	68 mm	± 1 mm
Outer rim (C)	75.5 mm	± 1 mm
Height (H)	36 mm	± 1 mm
Junction width (K)	56 mm	± 1 mm
Section width (L)	84 mm	± 1 mm
Cup basis weight	65 g/m ²	± 5 %
Tray basis weight	400 g/m ²	± 5 %
Section weight	2.3 g	± 5 %
Heat resistance	390° F max	



Characteristics - Tray

Tray configuration	3 x 4
Tray quantity	12
Tray measurement	252 mm x 336 mm
Tray material	Triple layered cardboard made from pure unbleached pulp.
Tray printing	Gold flower design on brown background.
Cup material	Grease resistant and wax-treated high density paper, manufactured from TCF pulp.
Ink	Resistant to heat, oil and alcohol up to recommended max baking temp of 390 degrees F.
FDA	Baking cup is manufactured in compliance with 21 CFR 176.170 and 176.180.
Kosher	Certified by KOF-K Supervision of Teaneck, New Jersey.
Country of origin	Italy

Additional specification documents available upon request.

Packaging and Storage

Case	20 in x 14 in x 17.5 in
Cube	2.836 ft ³
Case weight	Gross 17.1 lbs. Net 15.5 lbs.
Pieces/case	250 trays (3000 cavities)
Pallet	25 boxes at 92" high
Tie/high	5 boxes per 5 levels
Pieces/pallet	6,250 trays (75,000 cavities)
Box Label	Item code, description, quantity, production number, production date, and operator.
Storage	Dry conditions. Three year shelf life.
GTIN-14	18051768032450

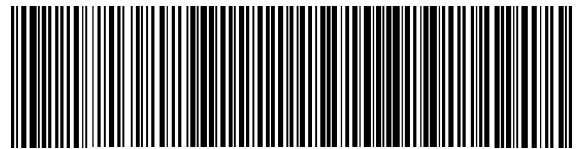

(01)18051768032450(10)123456(15)991231(422)380

Prepared	Approved	Date	Revision	Modifications
----------	----------	------	----------	---------------

C. Bruseghini
Quality Manager
C. Bruseghini

3/29/2018

5

Revision 5: General modifications.

NTS 2 White Muffin Tray 3x4

NTS Series

Technical Data - Individual Cup

G9F12005

		Tolerance
Bottom (A)	50 mm	± 1 mm
Top (B)	68 mm	± 1 mm
Outer rim (C)	75.5 mm	± 1 mm
Height (H)	36 mm	± 1 mm
Junction width (K)	56 mm	± 1 mm
Section width (L)	84 mm	± 1 mm
Cup basis weight	65 g/m ²	± 5 %
Tray basis weight	400 g/m ²	± 5 %
Section weight	2.3 g	± 5 %
Heat resistance	390° F max	



Technical Drawing

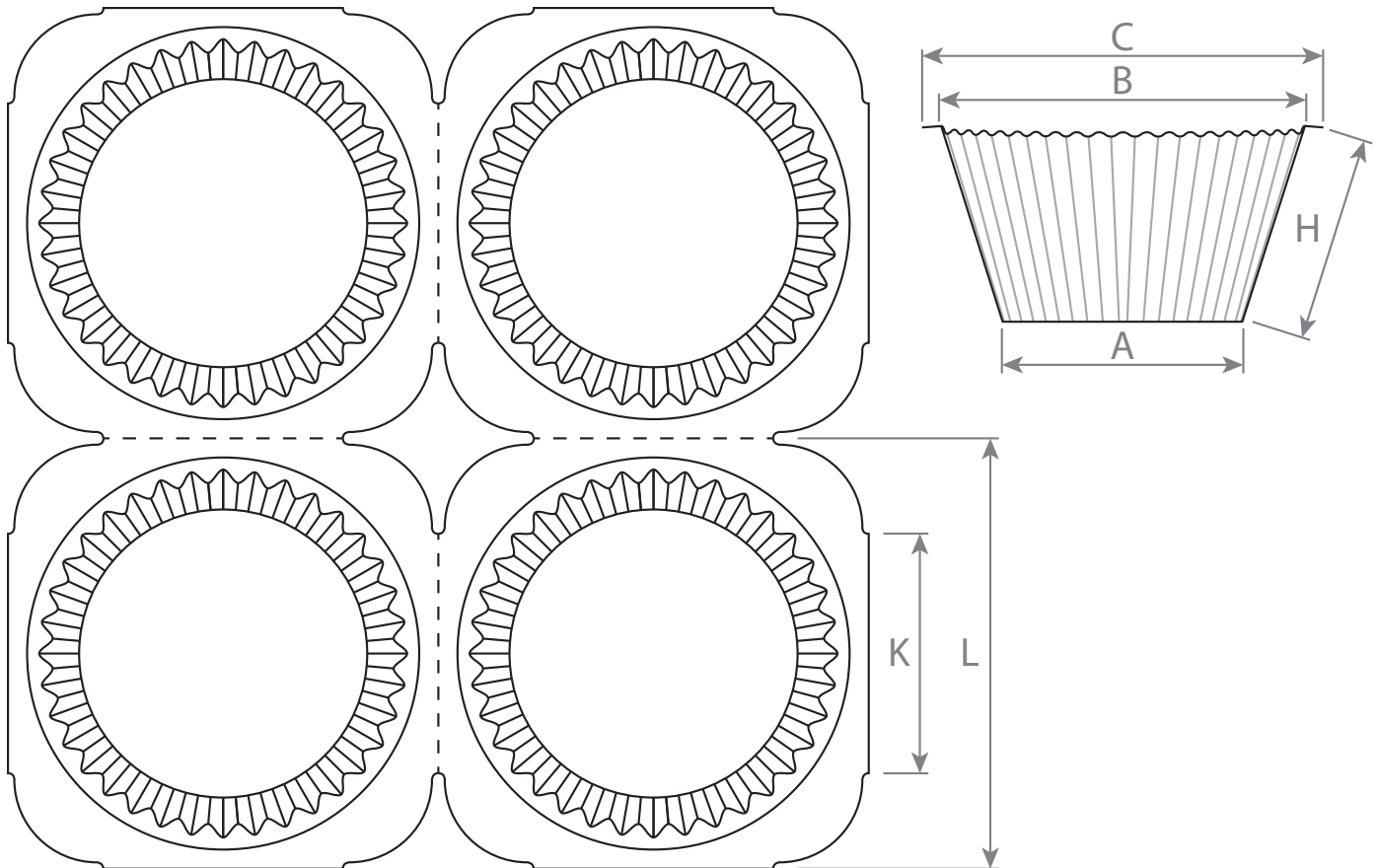

Prepared	Approved	Date	Revision	Modifications
 Quality Manager C. Bruseghini		3/29/2018	5	Revision 5: General modifications.