

PM 238 Siliconized

G9F10074

PM Series

Technical Data

		Tolerance
Bottom (A)	238 mm x 80 mm	± 1 mm
Top (B)	258 mm x 106 mm	± 1 mm
Top + flat rim (D)	124 mm	± 1 mm
Height (C)	70 mm	± 1 mm
Paper basis weight	170 g/m ²	± 5 %
Mold weight	17.6 g	± 5 %
Heat resistance	390° F max	



Characteristics

Material	Single face "F" flute corrugate created from two sheets of 60 GSM pure unbleached paper, highly calendered. The smooth face that creates the interior surface of the mold is then coated with food grade silicone, applied at 0.5 GSM. Exterior surface is printed.
Printing	Gold flower design on brown background, exterior is printed prior to corrugation.
Ink	Gold PMS 872 C, Brown PMS 504 C, resistant to heat, oil and alcohol up to the recommended max baking temperature of 390 degrees F.
Glue	Vinyl acetate, water based, used to attach side wall to the base of mold.
Starch	Maize (corn based) used in the corrugation process of the paper.
FDA	Mold is manufactured in compliance with 21 CFR 176.170 and 176.180.
Kosher	Certified by KOF-K Supervision of Teaneck, New Jersey.
Country of origin	Italy

Additional specification documents available upon request.

Packaging and Storage

Case	32 in x 16 in x 19.5 in
Cube	5.778 ft ³
Case weight	Gross 21.1 lbs. Net 18.8 lbs.
Pieces/case	480 pcs. (40 pcs. * 12 rows)
Pallet	3 boxes per 4 levels @ 82"
Pieces/pallet	5,760
Box Label	Item code, description, quantity, production number, production date, and operator.
Storage	Dry conditions. Three year shelf life.
GTIN-14	18051768030678

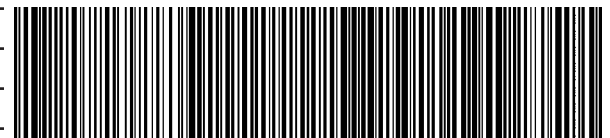

(01)18051768030678(10)123456(15)991231(422)380(91)000480

Prepared

Quality Manager
C. Bruseghini

Approved



Date

12/20/2017

Revision

5

Modifications

Rev. 5: General Modifications

PM 238 Siliconized

G9F10074

PM Series

Technical Data

		Tolerance
Bottom (A)	238 mm x 80 mm	± 1 mm
Top (B)	258 mm x 106 mm	± 1 mm
Top + flat rim (D)	124 mm	± 1 mm
Height (C)	70 mm	± 1 mm
Paper basis weight	170 g/m ²	± 5 %
Mold weight	17.6 g	± 5 %
Heat resistance	390° F max	



Technical Drawing

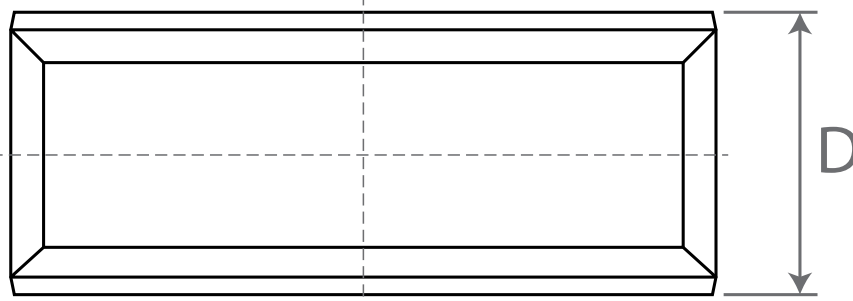
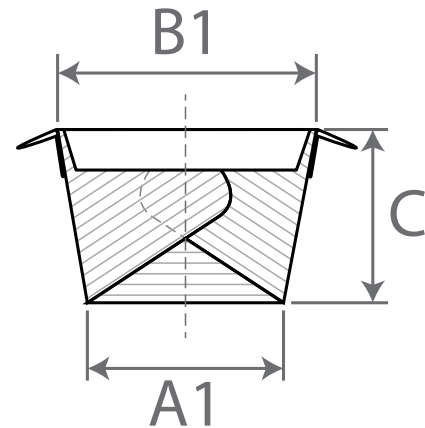
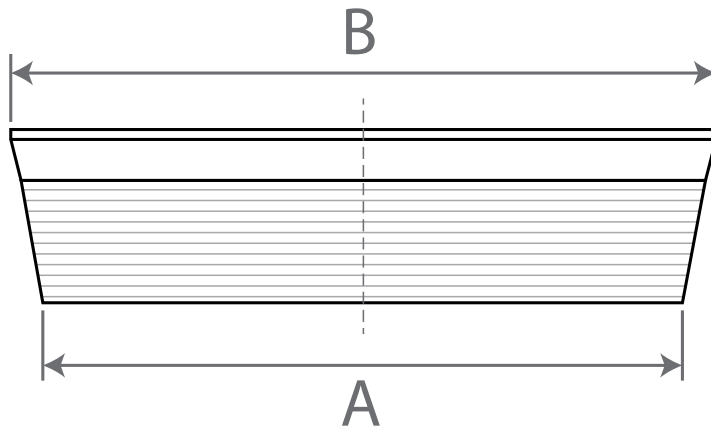

Prepared

C. Bruseghini
Quality Manager
C. Bruseghini

Approved

[Signature]

Date

12/20/2017

Revision

5

Modifications

Rev. 5: General Modifications